



TECTUL

PARTE E - INOXIDABLE

MATERIALES

CARACTERÍSTICAS

DISEÑO

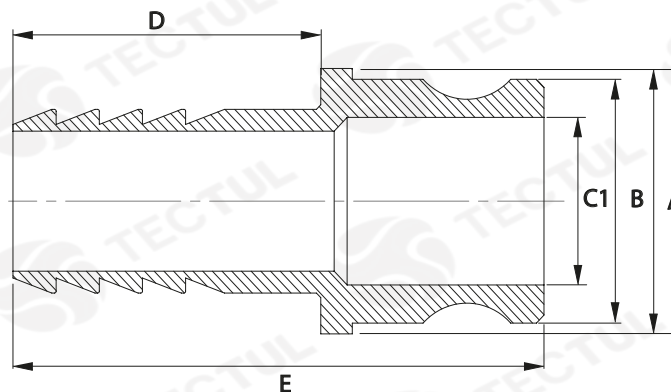

* Vista de sección transversal de tipo informativa. No representa una versión específica del accesorio de acero inoxidable.



CARACTERÍSTICAS FÍSICAS

Son accesorios de acople fácil y realizan trabajos de carga y descarga de productos. Se usa para gasolina, petróleo, petroquímicos, aire, alimentos.



MATERIALES

Están hechos de acero inoxidable A316 con empaque en nitrilo



NORMAS DE DISEÑO

Son fabricados de acuerdo a las normas DIN2828 - MIL-C-27487

DATOS TÉCNICOS

MEDIDA [in]	DIAMETRO INTERIOR 1 [mm] (C1)	LONGITUD TOTAL [mm] (E)	ANCHO MÁXIMO [mm] (A)	DIAMETRO EXTERIOR MANGUERA [mm] (B)	LONGITUD 2 [mm] (E-D)	PESO [g]
1/2"	14,00*	64,00*	29,00*	15,00*	29,00*	145,04*
3/4"	20,00*	84,00*	35,00*	21,00*	34,00*	207,20*
1"	25,00*	93,00*	38,00*	27,00*	37,00*	259,00*
1 1/4"	28,00*	104,00*	49,00*	34,00*	46,00*	290,08*
1 1/2"	36,00*	110,00*	58,00*	40,00*	49,00*	372,96*
2"	45,00*	128,00*	76,00*	53,00*	57,00*	466,20*
2 1/2"	55,00*	135,00*	79,00*	66,00*	57,00*	569,80*
3"	72,00*	160,00*	98,00*	78,00*	58,00*	745,92*
4"	96,00*	168,00*	122,00*	102,00*	60,00*	994,56*

* Fotos y medidas referenciales, sujetas a cambios sin previo aviso por parte del proveedor o fabricante.



TECTUL

PART E - STAINLESS

MATERIALS

PHYSICAL CHARACTERISTICS

DESIGN

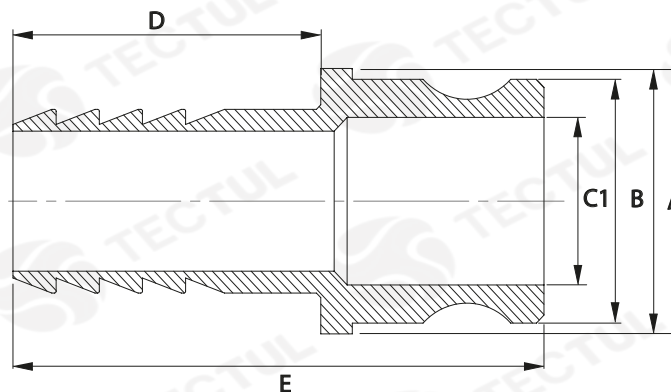

* Informational type cross section view. It does not represent a specific version of the the stainless steel accessory.

PHYSICAL CHARACTERISTICS

They are easy to attach accessories and perform product loading and unloading work. They are used for gasoline, oil, petrochemicals, air, food.

MATERIALS

They are made of A316 stainless steel with nitrile packing.

DESIGN STANDARDS

They are manufactured under the standards DIN2828-MIL-C-27487

TECHNICAL DATA

MEASURE [in]	INTERNAL DIAMETER 1[mm] (C1)	TOTAL LENGTH [mm] (E)	MAX WIDTH [mm] (A)	EXTERNAL HOSE DIAMETER [mm] (B)	LENGHT 2 [mm] (E-D)	WEIGHT [g]
1/2"	14,00*	64,00*	29,00*	15,00*	29,00*	145,04*
3/4"	20,00*	84,00*	35,00*	21,00*	34,00*	207,20*
1"	25,00*	93,00*	38,00*	27,00*	37,00*	259,00*
1 1/4"	28,00*	104,00*	49,00*	34,00*	46,00*	290,08*
1 1/2"	36,00*	110,00*	58,00*	40,00*	49,00*	372,96*
2"	45,00*	128,00*	76,00*	53,00*	57,00*	466,20*
2 1/2"	55,00*	135,00*	79,00*	66,00*	57,00*	569,80*
3"	72,00*	160,00*	98,00*	78,00*	58,00*	745,92*
4"	96,00*	168,00*	122,00*	102,00*	60,00*	994,56*

* Reference photos and measurements, subject to change without prior notice from the supplier or manufacturer.