



TECTUL

CODO 90° - COBRE

DISEÑO



CARACTERÍSTICAS



MATERIALES

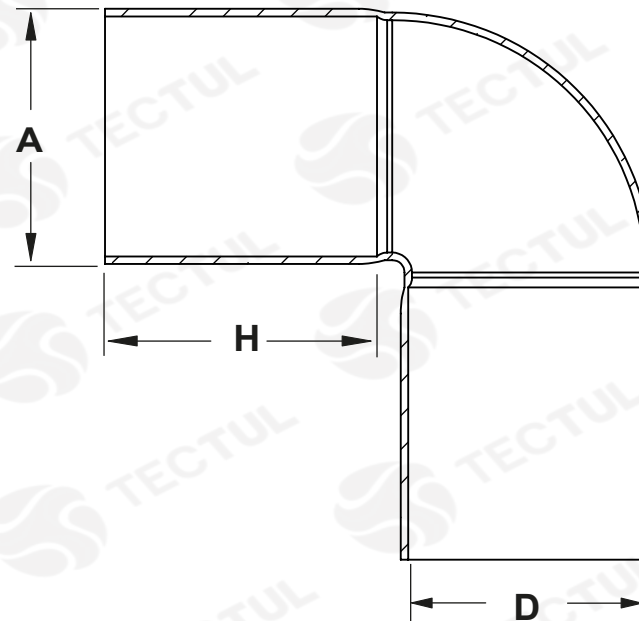

* Vista de sección transversal de tipo informativa. No representa una versión específica del accesorio de cobre.

MATERIALES



Están diseñados para sistemas de agua potable, calefacción, aire acondicionado, gases medicinales y energía solar térmica.

CARACTERÍSTICAS FÍSICAS



Los accesorios fundidos son ofrecidos en aleaciones de cobre. Cumple con los estándares de diseño ASME/ANSI B16.22 y ASME/ANSI B16.18

CARACTERÍSTICAS DIMENSIONALES



Son fabricados de acuerdo a las especificaciones B584 de ASTM, ASTM B75 de aleación C12200

DATOS TÉCNICOS

MEDIDA	DISTANCIA A CENTRO [mm] (A)	DIAMETRO INTERNO [mm] (D)	PROFUNDIDAD [mm] (H)	PESO [g]
1/2"	28,00*	14,45*	18,00*	18,14*
3/4"	44,00*	20,60*	28,00*	40,82*
1"	53,00*	26,79*	31,00*	68,03*

* Fotos y medidas referenciales, sujetas a cambios sin previo aviso por parte del proveedor o fabricante.



TECTUL

ELBOW 90° - COPPER

DESING



CHARACTERISTICS



MATERIALS

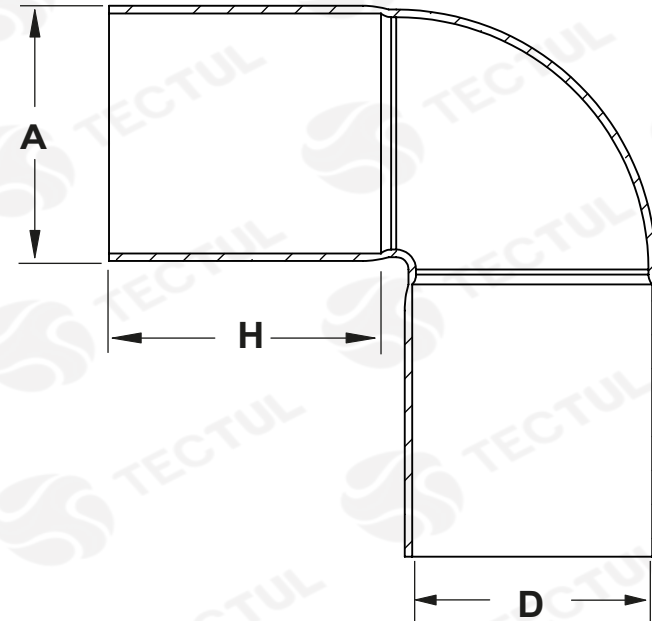

* Informational type cross section view. It does not represent a specific version of the copper fitting.

MATERIALS



They are designed for water drinking systems, heating, air-conditioning, medicinal gases and thermal solar energy.

PHYSICAL CHARACTERISTICS



Cast fittings are offered in copper alloys. Meets the ASME / ANSI B16.22 design standards and ASME / ANSI B16.18.

DIMENSIONAL CHARACTERISTICS



They are manufactured under the standards NTC 382, NTC 1339 and NTC 576.

TECHNICAL DATA

MEASURE	DISTANCE TO CENTER [mm] (A)	INTERNAL DIAMETER [mm] (D)	DEPTH [mm] (H)	WEIGHT [g]
1/2"	28,00*	14,45*	18,00*	18,14*
3/4"	44,00*	20,60*	28,00*	40,82*
1"	53,00*	26,79*	31,00*	68,03*

* Reference photos and measurements, subject to change without prior notice from the supplier or manufacturer.