



TECTUL

CODO 45° SOL.DABLE INOXIDABLE SCHEDULE 10

MATERIALES

CARACTERÍSTICAS FÍSICAS



CARACTERÍSTICAS DIMENSIONALES

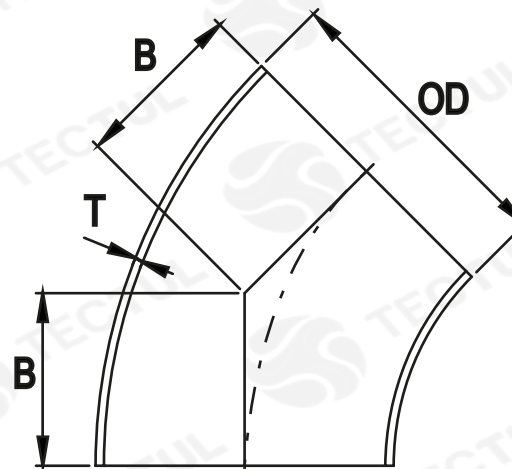

* Vista de sección transversal de tipo informativa. No representa una versión específica del accesorio o elemento.

MATERIALES

Fabricados acero inoxidable
ASTM A403 304/304L

CARACTERÍSTICAS FÍSICAS

Accesorios con conexión soldable
Butt Weld. Para conducción de gases,
ácidos, azucareras y proceso de alimentos

CARACTERÍSTICAS DIMENSIONALES

Dimensiones básicas según la Norma
Nacional estadounidense.
ANSI/ASME B16.9 con extremos biselados

DATOS TÉCNICOS				
MEDIDA	DIÁMETRO EXTERIOR (OD) [mm]	ESPESOR (T) [mm]	CENTRO A FINAL (B) [mm]	PESO [g]
1/2"	21,34*	2,11*	15,75*	39*
3/4"	26,67*	2,11*	11,18*	64*
1"	33,53*	2,77*	22,35*	103*
1-1/4"	42,26*	2,77*	25,40*	142*
1-1/2"	48,23*	2,77*	28,45*	571*
2"	60,45*	2,77*	50,80*	406*
2-1/2"	73,15*	3,05*	44,45*	571*
3"	88,90*	3,05*	50,80*	764*
4"	114,30*	3,05*	63,50*	985*

* Fotos y medidas referenciales, sujetas a cambios sin previo aviso por parte del proveedor o fabricante.



TECTUL

BUTT WELD ELBOW 45° STAINLESS SCHEDULE 10

MATERIALS

PHYSICAL CHARACTERISTICS

DIMENSIONAL CHARACTERISTICS

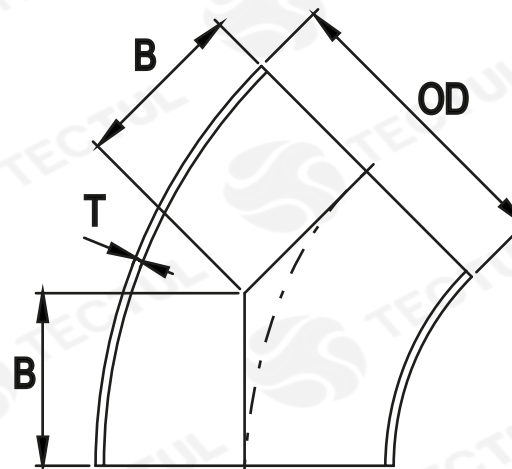

* Informational cross-sectional view. Does not represent a specific version of the accessory or item.

MATERIALS

Made of stainless steel
ASTM A403 304/304L

PHYSICAL CHARACTERISTICS

Accessories with solder connection
Butt Weld. for gas conduction,
acids, sugar and food processing

DIMENSIONAL CHARACTERISTICS

Basic dimensions according to the Standard
American National.
ANSI/ASME B16.9 with beveled ends

TECHNICAL DATA				
MEASURE	EXTERNAL DIAMETER (OD) [mm]	THICKNESS (T) [mm]	DISTANCE BETWEEN CENTERS (B) [mm]	WEIGHT [g]
1/2"	21,34*	2,11*	15,75*	39*
3/4"	26,67*	2,11*	11,18*	64*
1"	33,53*	2,77*	22,35*	103*
1-1/4"	42,26*	2,77*	25,40*	142*
1-1/2"	48,23*	2,77*	28,45*	571*
2"	60,45*	2,77*	50,80*	406*
2-1/2"	73,15*	3,05*	44,45*	571*
3"	88,90*	3,05*	50,80*	764*
4"	114,30*	3,05*	63,50*	985*

* Reference photos and measurements, subject to change without prior notice from the supplier or manufacturer.