



# TECTUL

## UNIÓN - CLASE 150

### MATERIALES

### CARACTERÍSTICAS FÍSICAS

### CARACTERÍSTICAS DIMENSIONALES

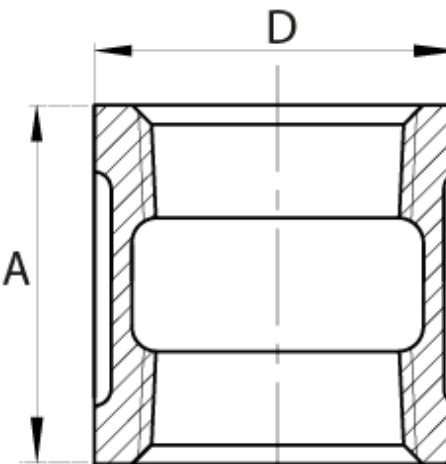

\* Vista de sección transversal de tipo informativa. No representa una versión específica del accesorio o elemento.



### DATOS TÉCNICOS

MEDIDA	ALTURA [mm] (A)	DIÁMETRO EXTERNO [mm] (D)	PASO DE ROSCA [H/In]	PESO [g]
1/4"	27,00*	23,00*	18	41*
3/8"	31,00*	27,00*	18	58*
1/2"	36,00*	30,00*	14	67*
3/4"	39,00*	37,00*	14	109*
1"	45,00*	44,00*	11,5	157*
1-1/4"	51,00*	53,00*	11,5	267*
1-1/2"	55,00*	59,00*	11,5	315*
2"	65,00*	77,00*	11,5	627*
2-1/2"	73,00*	93,00*	8	1097*
3"	79,00*	102,00*	8	1514*
4"	94,00*	138,00*	8	2623*
6"	108,00*	200,00*	8	6500*

\* Fotos y medidas referenciales, sujetas a cambios sin previo aviso por parte del proveedor o fabricante.



### MATERIALES

Fabricado en hierro maleable negro  
Recubierto ASTM A-197  
ASTM A153 HOT-DIP (Caliente)



### CARACTERÍSTICAS FÍSICAS

Cumple con los estándares de diseño  
ANSI/ASME B16.3 y B16.14.  
Extremos reforzados y estándar UL/FM



### CARACTERÍSTICAS DIMENSIONALES

Dimensiones básicas según la Norma  
Nacional estadounidense. Con conexión  
roscada NPT según ANSI/ASME B1.20.1



# TECTUL

## COUPLING - CLASS 150

### MATERIALS

### PHYSICAL CHARACTERISTICS

### DIMENSIONAL CHARACTERISTICS

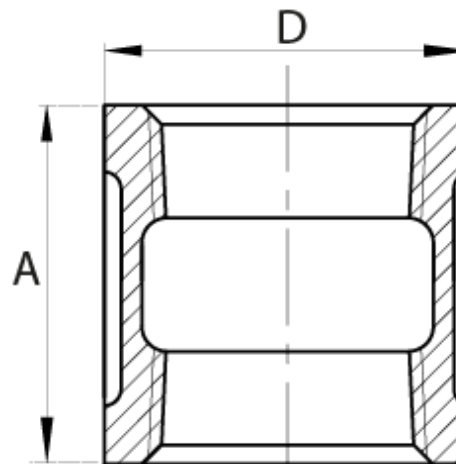

\* Informational cross-sectional view. Does not represent a specific version of the accessory or item.

**MATERIALS**

Made of black malleable iron  
ASTM A-197 coated  
ASTM A153 HOT-DIP (Hot)

**PHYSICAL CHARACTERISTICS**

Meet design standards  
ANSI/ASME B16.3 and B16.14.  
UL/FM standard and reinforced ends

**DIMENSIONAL CHARACTERISTICS**

Basic dimensions according to the Standard  
National American. With threaded  
connection NPT per ANSI/ASME B1.20.1

TECHNICAL DATA				
MEASURE	HEIGHT [mm] (A)	EXTERNAL DIAMETER [mm] (D)	THREAD PITCH [H/In]	WEIGHT [g]
1/4"	27,00*	23,00*	18	41*
3/8"	31,00*	27,00*	18	58*
1/2"	36,00*	30,00*	14	67*
3/4"	39,00*	37,00*	14	109*
1"	45,00*	44,00*	11,5	157*
1-1/4"	51,00*	53,00*	11,5	267*
1-1/2"	55,00*	59,00*	11,5	315*
2"	65,00*	77,00*	11,5	627*
2-1/2"	73,00*	93,00*	8	1097*
3"	79,00*	102,00*	8	1514*
4"	94,00*	133,00*	8	2623*
6"	108,00*	200,00*	8	6500*

\* Reference photos and measurements, subject to change without prior notice from the supplier or manufacturer.