



TECTUL

ABRAZADERA INDUSTRIAL INOXIDABLE

MATERIALES

CARACTERÍSTICAS FÍSICAS



CARACTERÍSTICAS DIMENSIONALES

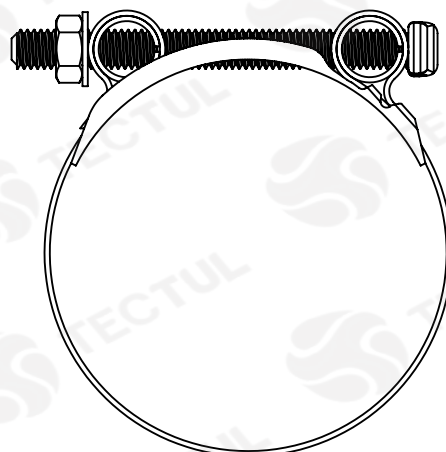
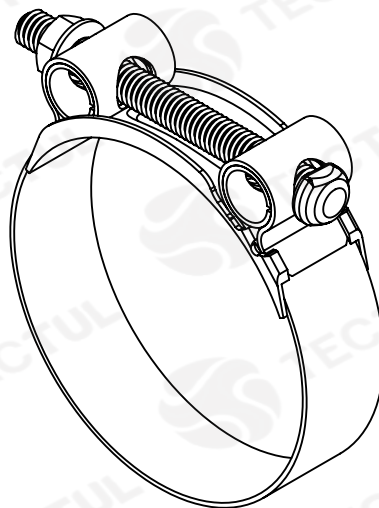

MATERIALES

Fabricado en acero inoxidable grado 304.



CARACTERÍSTICAS FÍSICAS

Cumple con los estándares de diseño ANSI / ASME B16.3 y B16.14, Extremos reforzados y estándar UL / FM



CARACTERÍSTICAS DIMENSIONALES

Dimensiones básicas según la Norma Nacional estadounidense. Con conexión roscada NPT según ANSI / ASME B1.20.1

DATOS TÉCNICOS

REFERENCIA	DIÁMETRO MANGUERA [in]	RANGO [mm]
UCG29-31	1"	29 - 31
UCG30-33	1"	30 - 33
UCG32-35	1"	32 - 35
UCG34-37	1"	34 - 37
UCG36-39	1"	36 - 39
UCG38 - 41	1 1/4"	38 - 41
UCG40 - 43	1 1/4"	40 - 43
UCG44 - 47	1 1/4"	44 - 47
UCG48 - 51	1 1/2"	48 - 51
UCG52 - 55	1 1/2"	52 - 55
UCG56 - 59	1 1/2"	56 - 59
UCG60 - 63	2"	60 - 63
UCG64 - 67	2"	64 - 67
UCG68 - 73	2"	68 - 73
UCG 74 - 79	2"	74 - 79
UCG76 - 80	2 1/2"	76 - 80
UCG80 - 85	2 1/2"	80 - 85
UCG86 - 91	2 1/2"	86 - 91
UCG92 - 97	3"	92 - 97
UCG98 - 103	3"	96 - 102
UCG104 - 112	3"	104 - 112
UCG110 - 118	4"	110 - 118
UCG113 - 121	4"	113 - 121
UCG122 - 130	4"	122 - 130
UCG131 - 139	4"	131 - 139
UCG140 - 148	5"	140 - 148
UCG149 - 161	5"	149 - 161
UCG162 - 174	5"	162 - 174
UCG175 - 187	6"	175 - 187
UCG188 - 200	6"	188 - 200
UCG195 - 210	6"	195 - 210
UCG201 - 213	6"	201 - 213
UCG214 - 223	6"	214 - 223

* Fotos y medidas referenciales, sujetas a cambios sin previo aviso por parte del proveedor o fabricante.



TECTUL

STAINLESS INDUSTRIAL CLAMP

MATERIALS



PHYSICAL CHARACTERISTICS



DIMENSIONAL CHARACTERISTICS

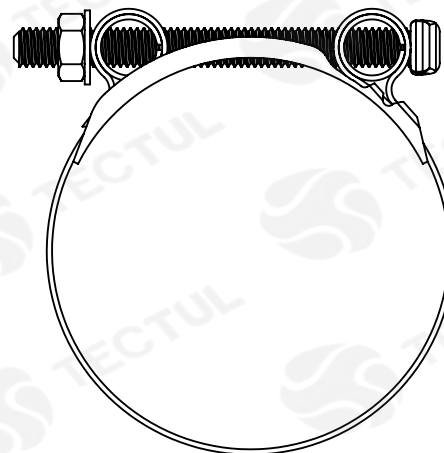
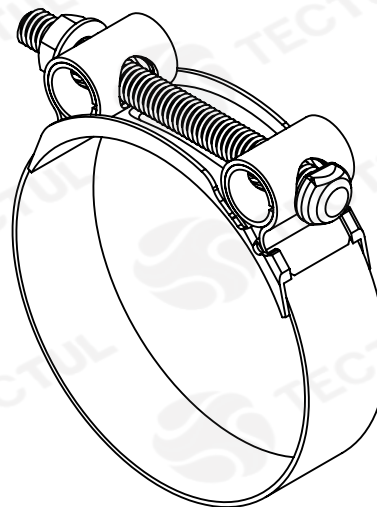

MATERIALS

Made of 304 grade stainless steel



PHYSICAL CHARACTERISTICS

Meet design standards
ANSI / ASME B16.3 and B16.14,
UL / FM standard and reinforced ends



DIMENSIONAL CHARACTERISTICS

Basic dimensions according to the Standard
National American. With threaded connection
NPT per ANSI / ASME B1.20.1

TECHNICAL DATA

REFERENCE	HOSE DIAMETER [in]	RANGE [mm]
UCG29-31	1"	29 - 31
UCG30-33	1"	30 - 33
UCG32-35	1"	32 - 35
UCG34-37	1"	34 - 37
UCG36-39	1"	36 - 39
UCG38 - 41	1 1/4"	38 - 41
UCG40 - 43	1 1/4"	40 - 43
UCG44 - 47	1 1/4"	44 - 47
UCG48 - 51	1 1/2"	48 - 51
UCG52 - 55	1 1/2"	52 - 55
UCG56 - 59	1 1/2"	56 - 59
UCG60 - 63	2"	60 - 63
UCG64 - 67	2"	64 - 67
UCG68 - 73	2"	68 - 73
UCG 74 - 79	2"	74 - 79
UCG76 - 80	2 1/2"	76 - 80
UCG80 - 85	2 1/2"	80 - 85
UCG86 - 91	2 1/2"	86 - 91
UCG92 - 97	3"	92 - 97
UCG98 - 103	3"	96 - 102
UCG104 - 112	3"	104 - 112
UCG110 - 118	4"	110 - 118
UCG113 - 121	4"	113 - 121
UCG122 - 130	4"	122 - 130
UCG131 - 139	4"	131 - 139
UCG140 - 148	5"	140 - 148
UCG149 - 161	5"	149 - 161
UCG162 - 174	5"	162 - 174
UCG175 - 187	6"	175 - 187
UCG188 - 200	6"	188 - 200
UCG195 - 210	6"	195 - 210
UCG201 - 213	6"	201 - 213
UCG214 - 223	6"	214 - 223

* Reference photos and measurements, subject to change without prior notice from the supplier or manufacturer.